

Heavy Duty 6 & 10

CONDENSATE REMOVAL PUMP

With an impressive flow rate, these robust and reliable Heavy Duty pumps are perfect for the rapid removal of large quantities of condensate water.



HD6 : Max. flow 900 l/h
HD10 : Max. flow 1070 l/h



HD6: 6m max. rec. head
(flow rate 180L/h)
HD10: 9m max. rec. head
(flow rate 100L/h)

Key Features

- High flow rate
- Non return valve
- Easy installation
- 4 litre tank capacity

Suitability

- HD6 : Up to 1200 kW (4m Btu/h)
- HD10 : Up to 1460 kW (4.9m Btu/h)
- Dehumidifiers; Air handling units (AHUs)
- **Perfect for...** Large volumes of water

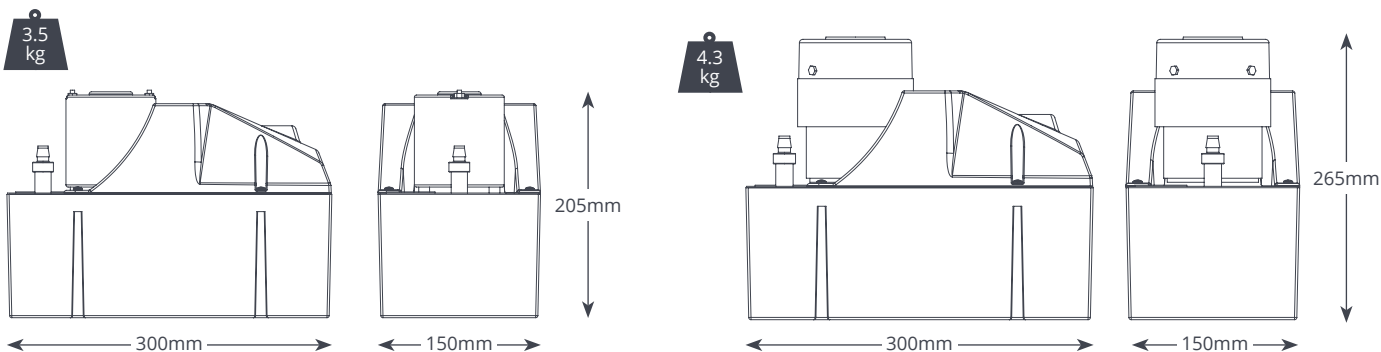

@ 230 VAC 50Hz	
Max. flow	HD6 : 900 L/h, HD10 : 1070 L/h
Max. rec. head	HD6 : 7m, HD10 : 9m
Tank capacity	4L
dB(A) @1m	HD6 : 60dB(A), HD10 : 64dB(A)
Power supply	HD6: 230 VAC, 50Hz, 1.5A HD10: 230 VAC, 50Hz, 0.38A
Rated	HD6: Non continuous HD10: Continuous
Class	I
Max. unit output	HD6: 1200kW (4m Btu/h) HD10: 1460kW (4.9m Btu/h)
Max. water output	40°C (104°F)
Inlet/Outlet	2x 40mm in, 10mm out
IP Protection	IP20
Safety Switch	3.0A Normally closed

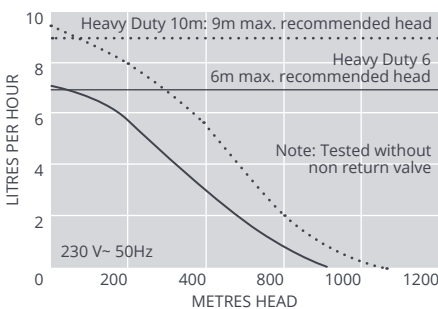

OPTIONS	
Heavy Duty 6	FP2074/2
Heavy Duty 10	FP2066/2

SUGGESTED XTRA ACCESSORIES		
Description		Part No.
Pipe to Pipe connector 16 mm–21 mm		FP2018
Tube to Soil Stack Adaptor		FP2038
Vinyl Tube Braided 3/8" (10 mm)		AX5101

For more installation accessories take a look at our Aspen Xtra range

IN THE BOX
Heavy Duty 6 or 10 pump • 2m power cable • Install manual

Download manual at aspenspumps.com