

Hot Water Economy 6m

CONDENSATE REMOVAL PUMP

Built of heat resistant cycloloy, this economy pump is designed to handle high water temperatures. Not suitable for demineralised water.



900 L/h max. flow



6m max. rec. head 6m
(Flow rate 180 l/h)

Key Features

- High performance
- Handles 100°C water
- 2 Inlets

Suitability

- Up to 1200kW (4m Btu/h)
- Humidifiers; Boilers; Refrigeration; Air handling units (AHUs)
- **Perfect for...** Hot water

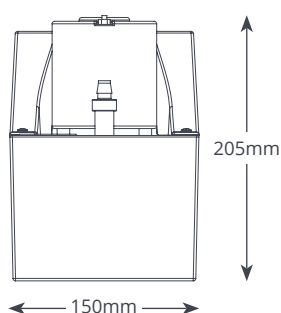
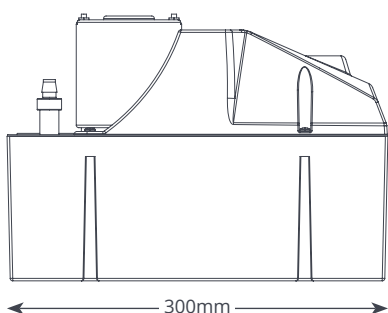

@ 230 VAC 50Hz	
Max. flow	900L/h @ 0m head
Max. rec. head	6m
Tank capacity	4L
dB(A) @1m	60dB(A)
Power supply	6m: 230 V~, 1.5A, 50Hz 9m: 230 V~, 0.49A, 50Hz
Rated	Non continuous
Class	I
Max. unit output	1200kW (4m Btu/h)
Max. water output	100°C (212°F)
Inlet/Outlet	2x 40mm in, 10mm out
IP Protection	IP20
Safety Switch	3.0A Normally closed
Thermal protection	✓
Fully potted	n/a
Self priming	n/a

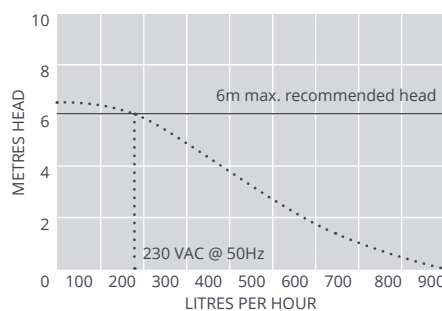

OPTIONS	
Hot Water Economy 6 m	FP2092/2

SUGGESTED XTRA ACCESSORIES		
Description		Part No.
Pipe to Pipe connector 16mm-21mm		FP2011
Tube to Soil Stack Adaptor		FP2038
Vinyl Tube Braided 3/8" (10mm)		AX5111

For more installation accessories take a look at our Aspen Xtra range

IN THE BOX
Hot Water Economy Pump • 2m power cable • Install manual

Download manual at aspenspumps.com